

Low Current Measurements

Basic Current Measurements

In a typical circuit (see *Figure 1a*), a source causes a current (I) to flow through the circuit. The goal of any electrical current measurement is to insert an ammeter in series with the circuit so that the current measured on the ammeter is identical to the current originally flowing through the circuit. To do so, the circuit is broken between points A and B, and the meter is connected as shown in *Figure 1b*. In the ideal case, the meter would have absolutely no effect on the circuit. For practical measurements, however, several error sources may be present. These error sources can result in substantial uncertainty in the measurement, as we will now discuss.

Any ammeter can be modeled to consist of the three separate circuit elements shown in *Figure 1b*: a shunt resistance (R_{SH}) caused by the input cable connected to the meter; a generator of unwanted current (I_C), which represents mainly currents generated by interconnections; and an internal resistance (R_M), which includes series cable resistance. Note that R_M is in series with an ideal ammeter (M_I), having no resistance or current source of its own.

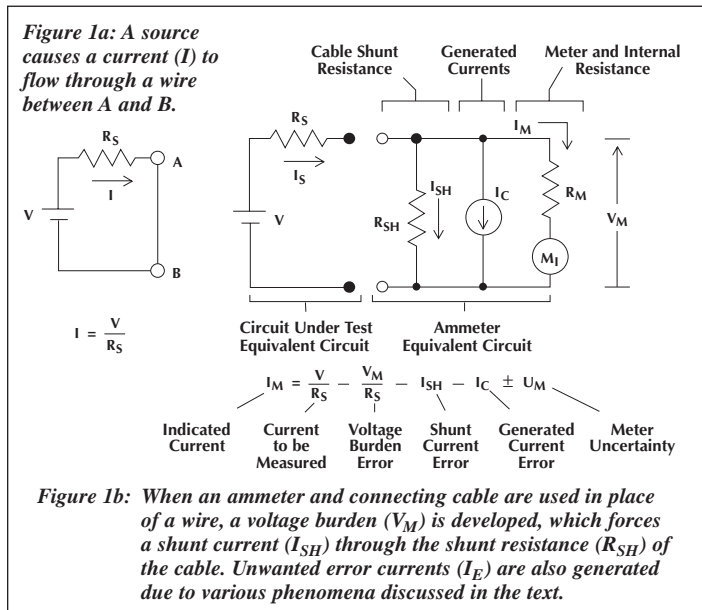

When the ammeter is connected in the circuit to be measured, the current indicated on the meter is equal to the current that would flow through the circuit without the ammeter inserted in the circuit, less errors caused by elements in the circuit model. These errors consist of current flowing through the model shunt resistance, currents generated by the interconnections, errors

induced by the voltage burden (or drop) across the entire ammeter model, and the uncertainty of the meter itself.

With measurements of currents in the normal range (typically $>1\text{mA}$), errors caused by ammeter voltage burden, shunt currents, and noise current are often small enough to be ignored. In these cases, the displayed current reading is simply equal to the actual current plus or minus inherent meter uncertainty, (U_M). Meters designed to measure these normal currents generally consist of a voltmeter circuit that measures the voltage drop across a shunt resistor inserted in the series with the circuit being measured. (See the discussion on shunt ammeters that follows.) The reading provided by the voltmeter is thus directly proportional to the current flow.

Unfortunately, the voltage burden (input voltage drop) produced by such meters usually ranges from 200mV to about 2V. This voltage drop is sufficient to cause errors with current measurements below the normal range. To avoid such large voltage drops, picoammeters and electrometers use a high gain amplifier with negative feedback for the input stage. As a result, the voltage burden is greatly reduced—on the order of 200 μV or less. This low voltage burden reduces both measurement errors and the minimum shunt cable resistance that must be maintained to provide a given meter accuracy. Consequently, no special measures need be taken to obtain unusually high cable resistance.

Typical picoammeters or electrometers that employ feedback ammeters generally provide sensitivities to 1fA (10^{-15}A) or less and typical accuracy of 0.1% to 3%.

Shunt vs. Feedback Ammeters

There are two basic techniques for making low current measurements: the shunt method, and the feedback ammeter technique. The shunt configuration is used primarily in DMMs (digital multimeters) and in older electrometers where cable capacitance causes problems in the feedback mode. Picoammeters and newer electrometers use only the feedback ammeter configuration. The major difference between picoammeters and electrometers is that electrometers are multifunction instruments, while picoammeters measure only current. Also, a typical electrometer may have several decades better current sensitivity than the typical picoammeter.

Shunt Picoammeter

Shunting the input of an electrometer voltmeter with a resistor forms a shunt ammeter, as shown in *Figure 2*. The input current

(I_{IN}) develops an input voltage E_{IN} across the shunt resistance (R_{SHUNT}) as follows:

$$E_{IN} = I_{IN}R_{SHUNT}$$

Note that the voltage sensitivity of the circuit is controlled both by the value of R_{SHUNT} and the relative values of R_A and R_B . Thus, the output voltage (E_{OUT}) is given by:

$$E_{OUT} = E_{IN} \left(\frac{R_A + R_B}{R_B} \right) = I_{IN}R_{SHUNT} \left(\frac{R_A + R_B}{R_B} \right)$$

Although it might appear advantageous to use a larger value for R_{SHUNT} , there are actually several good reasons why R_{SHUNT} should be made as small as possible. First, low value resistors have better time and temperature stability, and a better voltage coefficient than high value resistors. Second, low resistor values reduce the input time constant and result in faster instrument response times. Finally, for circuit loading considerations, the input resistance R_{SHUNT} of an ammeter should be small to reduce the voltage burden E_{IN} .

However, using an electrometer (or any voltmeter) on its most sensitive range introduces noise and zero drift into the measurement. In contrast, Johnson noise current decreases as the value of R_{SHUNT} increases. Thus, some compromise between these two opposing requirements is usually necessary. Choosing a 1–2V full-scale sensitivity and the appropriate shunt resistance value is often a good compromise.

Feedback Picoammeter

Figure 3 shows the general configuration of a feedback type ammeter. In this configuration, the input current (I_{IN}) flows into the input terminal of the amplifier (A), and it also flows through the feedback resistor (R_F). The low offset current of the amplifier changes the current (I_{IN}) by a negligible amount.

Thus, the output voltage is a measure of the input current, and sensitivity is determined by the feedback resistor (R_F). The low voltage burden (E_{IN}) and corresponding fast rise time are achieved by the high gain operational amplifier, which forces E_{IN} to be nearly zero.

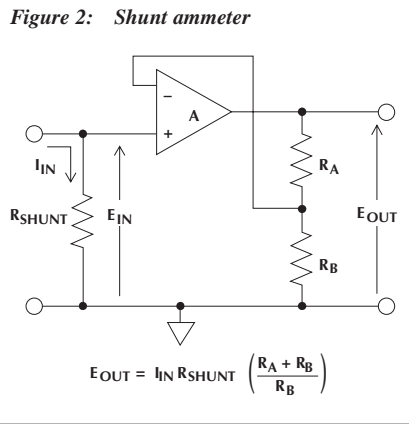

Circuit analysis shows that:

$$E_{OUT} + I_{IN}R_F = E_{IN} \quad E_{OUT} = -AE_{IN}, \text{ and } E_{IN} = -\frac{E_{OUT}}{A}$$

$$\text{Thus, } E_{OUT} + I_{IN}R_F = -\frac{E_{OUT}}{A} \text{ and } E_{OUT} \left(1 + \frac{1}{A} \right) = -I_{IN}R_F$$

$$\text{Since } A \gg 1, E_{OUT} = -I_{IN}R_F \text{ and } |E_{IN}| = \frac{E_{OUT}}{A} \ll E_{OUT}$$

Note that the amplifier gain can be changed as in the voltmeter circuit, using the combination shown in **Figure 4**. In this case, resistors R_A and R_B are added to the feedback loop, forming a multiplier. The gain of the circuit is determined by the feedback resistor and by the relative values of R_A and R_B and is given as follows:

$$E_{OUT} = -I_{IN}R_F \left(\frac{R_A + R_B}{R_B} \right)$$

$$\text{and again, } E_{IN} = -\frac{E_{OUT}}{A}$$

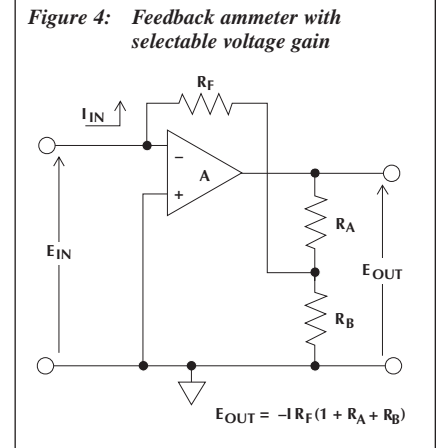

Sources of Current Errors

Errors in current-measuring instruments arise from extraneous currents flowing through various circuit elements. In the model circuit of **Figure 5**, the current (I_M), indicated on the meter, is actually equal to the current (I_1) through the meter, plus additional meter uncertainty (U_M). I_1 is the signal current (I_S), less shunt current (I_{SH}) and the sum of all generated currents (I_E).

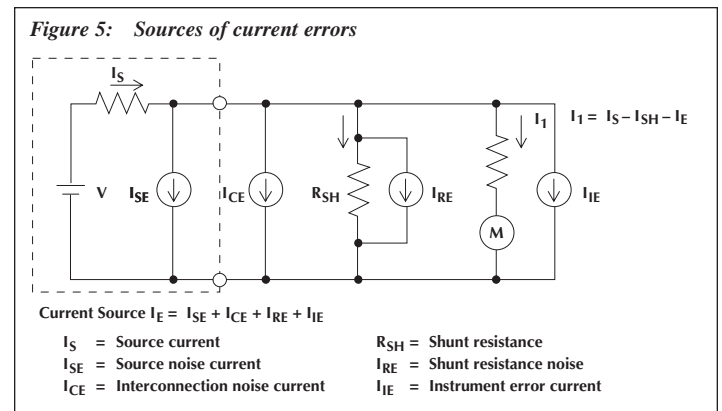

The circuit model shown in **Figure 5** identifies various noise and error currents generated during a typical current measurement. The I_{SE} current generator represents noise currents

generated within the source itself. These currents could arise due to leakage, piezoelectric, or triboelectric effects, or through dielectric absorption.

Similarly, the I_{CE} current generator represents currents generated in the interconnection between the meter and the source circuit. The same sources that generate noise currents in the circuit under test may produce noise in the interconnection. I_{RE} is generated by the thermal activity of the shunt resistance and the rms value of the noise current and is given by:

$$I_{RE} = \sqrt{4kTf/R_{SH}}$$

where: k = Boltzman's constant ($1.38 \times 10^{-23} \text{J/K}$)

T = absolute temperature in K

f = noise bandwidth in Hz

R_{SH} = resistance in ohms

Since peak-to-peak noise is about five times the rms value, the noise current can be ignored when measuring currents above 10^{-14}A .

Finally, I_{IE} is the specified sum of error currents in the measuring instrument.

Noise Currents

The noise current generators I_{CE} , I_{SE} , and I_{IE} in the above model represent unwanted currents generated at a particular point in the circuit. These currents may arise from triboelectric, piezo-electric, and electrochemical effects, or from resistive leakage or dielectric absorption.

Triboelectric currents (shown in **Figure 6**) are generated by charges created at the interface between a conductor and an insulator due to friction. Here, free electrons rub off the conductor and create a charge imbalance that causes a current flow. A typical example would be electrical currents generated by insulators and conductors rubbing together in a coaxial cable. Special low noise coax and triax cables are available to minimize this problem.

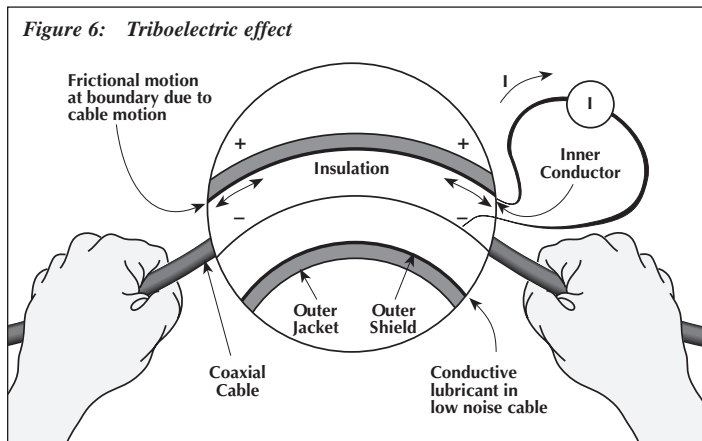

Piezoelectric currents (**Figure 7**) are generated when mechanical stress is applied to certain insulating materials. These currents are generated in ceramics and other crystalline materials used for insulating terminals and interconnecting hardware. Similar stored charge effects occur in many plastics.

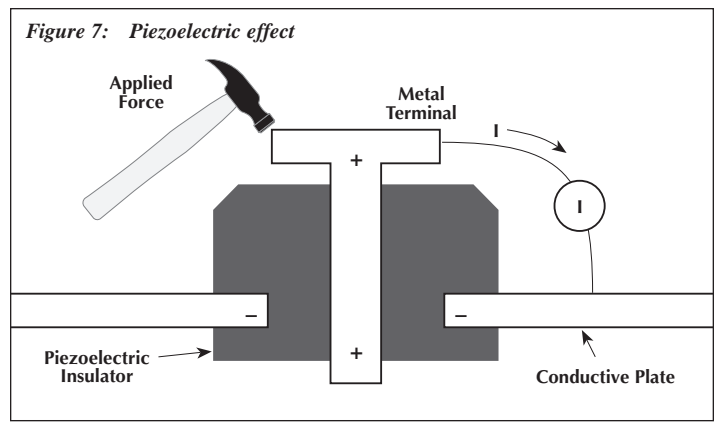

Noise currents also arise from electrochemical effects, which are shown in **Figure 8**. Here, chemicals cause weak batteries between two conductors on a circuit board.

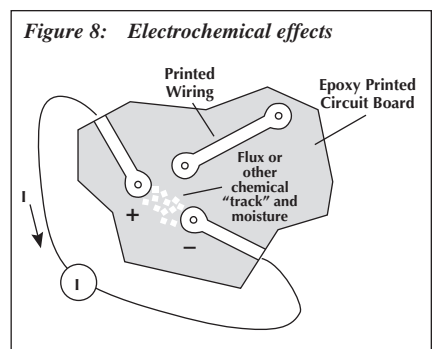

For example, commonly used epoxy printed circuit boards can generate currents of several nanoamps when not thoroughly cleaned of etching solution, flux, or other material. To prevent these error currents, all interconnecting circuitry should be thoroughly cleaned using a cleaning solvent such as methanol, and then be allowed to dry completely before use.

Dielectric absorption can occur when a voltage applied across an insulator causes positive and negative charges within that insulator to polarize. When the voltage is removed, the separated charges generate a decaying current through external circuitry as they recombine. The effects of dielectric absorption can be minimized by avoiding the application of voltages more than a few volts to insulators to be used for sensitive current measurements. If this practice is unavoidable, it may take minutes or even hours in some cases for currents caused by dielectric absorption to dissipate.

Figure 9 summarizes approximate magnitudes of the various current-generating effects.

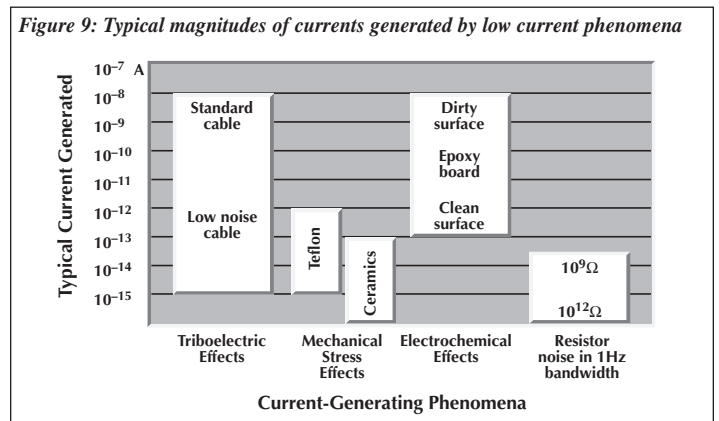

Guarding

High resistance paths between low current conductors and nearby voltage sources can cause significant leakage currents, which can be eliminated through guarding. Basically, guarding uses a conductor at the same potential as the sensitive current path to totally surround the input leads carrying the high impedance signals. This guard conductor is driven by a low impedance source, and maintaining the conductor at the same potential as the high-impedance source results in drastically reduced leakage currents from those leads.

For example, assume that an ammeter is to be used to measure the current I_D through the diode shown in **Figure 10a**. If the meter (a picoammeter or electrometer ammeter) is connected in series with the diode (**Figure 10b**), it will measure not only the diode current (I_D), but also the leakage current (I_L) that flows through the leakage resistance path (R_L). If R_L has a value of $1G\Omega$ ($10^9\Omega$, a reasonable value for many insulators), the leakage current (I_L) would be $15nA$ (assuming a $15V$ potential across the circuit, as shown).

Obviously, the large value of leakage current would obscure the actual diode leakage current (I_D), which is typically much lower than $15nA$ in modern diodes. One way to solve the problem is to increase the leakage resistance (R_L) to $1T\Omega$, reducing I_L to $15pA$, which still may be large compared to I_D .

Another way to reduce the effects of leakage currents is to guard the connection between the diode and the picoammeter so that it is completely surrounded by a conductor connected to the same potential ($+15V$ in this example). The resulting configuration is shown in **Figure 10c**. Since a typical feedback picoammeter has a maximum voltage burden of only $200\mu V$, the voltage across R_L is reduced to that value, and the leakage current now becomes:

$$I_L \leq \frac{200\mu V}{1G\Omega}$$

$$I_L \leq 2 \times 10^{-13}A \text{ (0.2pA)}$$

Thus, I_L is reduced by four decades and is likely to be insignificant compared to I_D .

The current flowing through R_G is still $15nA$, but it is now supplied by the low impedance $+15V$ source, and it does not present a problem since it is not measured by the ammeter.

Another situation where guarding is beneficial is shown in **Figure 11a**. In this case, the leakage resistance of a coaxial cable whose shield is grounded will reduce the output voltage of a high resistance source, as shown in **Figures 11a** and **11b**. Note that voltage actually measured by the high impedance voltmeter is attenuated by the voltage divider formed by the source resistance (R_S) and the leakage resistance (R_L).

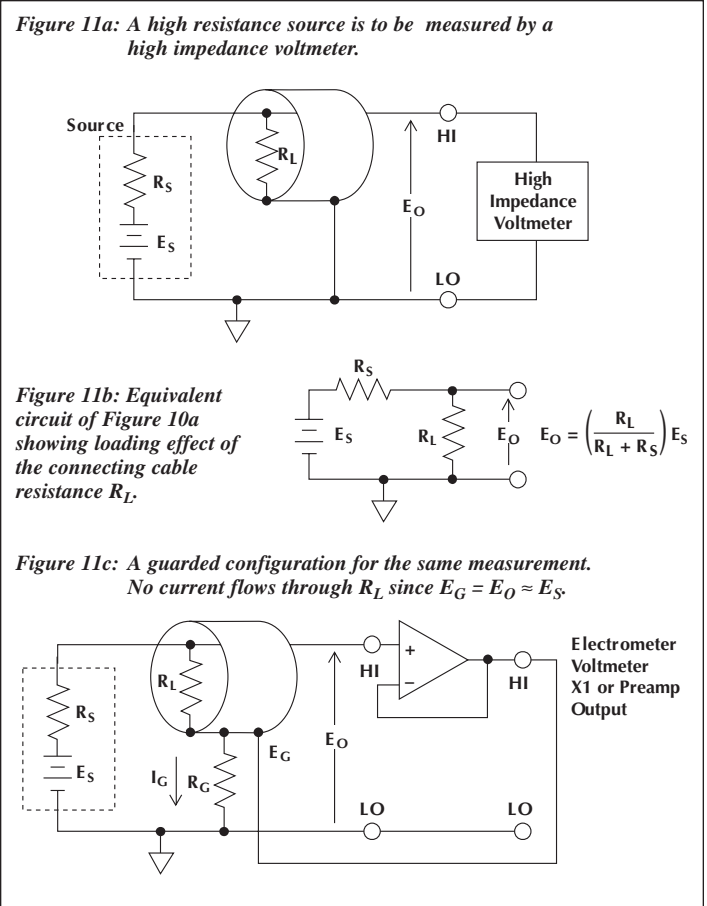
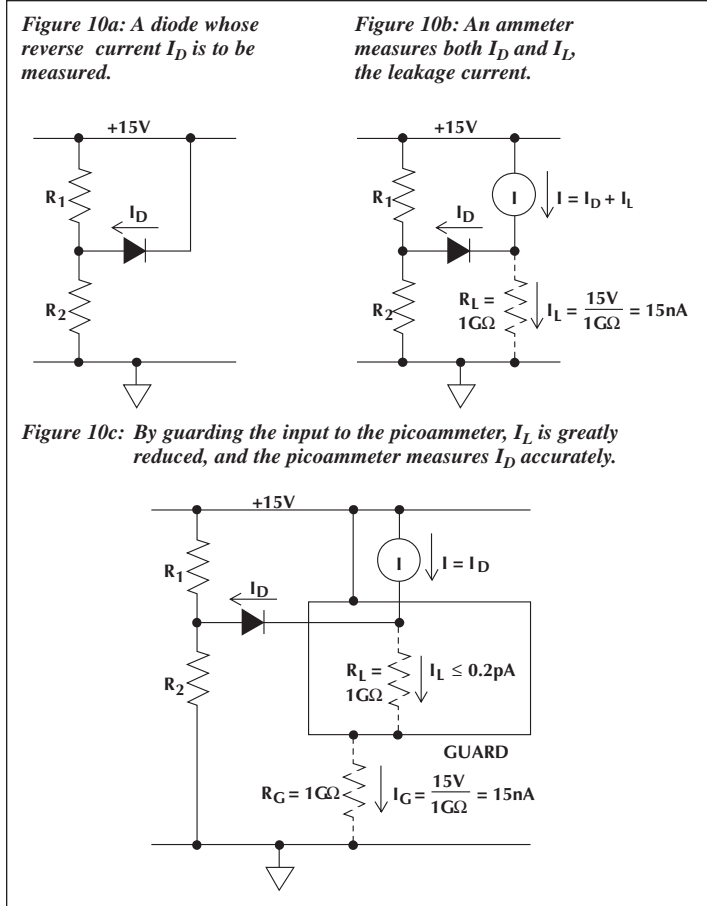

If instead, the shield is connected to a low impedance source of the same potential as the high resistance source, such as the unity-gain or preamp output of an electrometer voltmeter (*Figure 11c*), leakage from the center conductor to the shield will vanish, since there is essentially no potential across the insulator (R_L). Leakage current (I_G) from the outer guard shield to ground may be considerable, but it is of no consequence since the current is supplied by the low impedance preamp output rather than by the high impedance source.

Although the main advantage of guarding is in the reduction of leakage resistance effects, another is the reduction of effective input capacitance. Measurement rise time depends both on the equivalent source resistance and the effective meter input capacitance, which depends both on the electrometer input capacitance and the connecting cable capacitance. Thus, for high resistance measurements, even a small amount of cable capacitance can result in very long rise times. For example, an input capacitance of 1,000pF (including the input cable) and a resistance of 200G Ω results in a time constant of 200 seconds, and 1,000 seconds (more than 16 minutes) must be allowed for the measurement to settle to within 1% of final value.

Modern electrometers, such as the Models 6514, 6517A, and 6430, have built-in provisions to take full advantage of guarding. In the guarded mode, the effective cable capacitance can be reduced to about 20pF, speeding up measurements by a factor of 50.

High Resistance Measurements

When resistances $>1G\Omega$ must be measured, an electrometer is usually required. An electrometer may measure high resistance by either the constant voltage or the constant current method. Some electrometers allow the user to choose either method. The constant voltage method utilizes the electrometer ammeter and a voltage source, while the constant current method uses the electrometer voltmeter and a current source. A description of these techniques follows.

Constant Voltage Method

To make high resistance measurements using the constant voltage method, an electrometer ammeter or picoammeter and a constant voltage source are required. Some electrometers and picoammeters have voltage sources built into the instrument and can automatically calculate the resistance. This section describes this method and ways to reduce the leakage resistance due to test fixturing when making these measurements.

Basic Configuration

The basic configuration of the constant voltage method is shown in *Figure 12*. In this method, a constant voltage source (V) is placed in series with the unknown resistor (R) and an electrometer ammeter (I_M). Since the voltage drop across the ammeter is negligible, essentially all the voltage appears across R . The

Figure 12: Constant voltage method for measuring high resistance

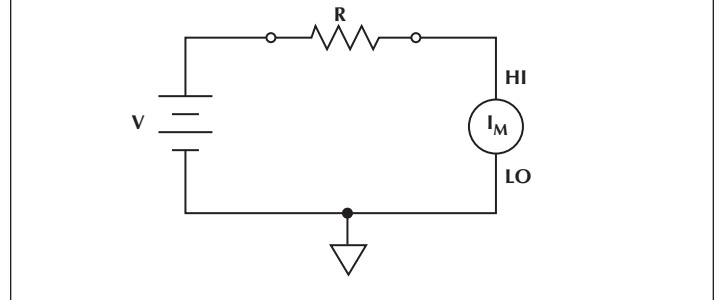

resulting current is measured by the ammeter and the resistance is calculated using Ohm's Law ($R = V/I$).

Because high resistance is often a function of the applied voltage, this method is preferred compared to the constant current method. By testing at several voltages, a resistance vs. voltage curve can be developed and a "voltage coefficient of resistance" can be determined. Some of the applications that use this method include testing two-terminal high resistance devices, measuring insulation resistance, and determining the volume and surface resistivity of insulating materials.

The constant voltage method requires using an electrometer ammeter, so all the techniques and errors sources apply to this method. One common error source when making high resistance measurements is due to the leakage resistance of the cables and fixturing. Two methods for eliminating fixture leakage are guarding and baseline suppression.

Baseline Suppression

Although the constant voltage method is suitable for measuring very high resistance values and is quite fast, some care should be taken to suppress any leakage currents present in the system. Otherwise, any leakage current adds to the test current, reducing resistance measurement accuracy. Such leakage currents can be nulled out by using baseline suppression.

Consider the test circuit shown in *Figure 13*. In this instance, the test resistance is removed from the system, and any leakage current flowing through $R_{LEAKAGE}$ is measured by the meter as $I_{LEAKAGE}$. At this point, the current suppression feature of the meter is enabled to null out the leakage current.

Figure 13: Leakage resistance ($R_{LEAKAGE}$) causes a current ($I_{LEAKAGE}$) to flow.

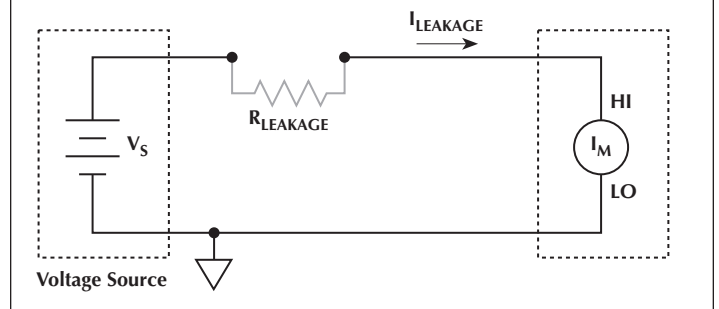
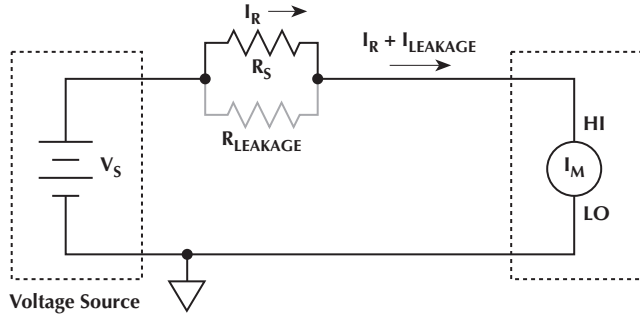

Figure 14: Baseline suppression cancels leakage current.



$$\text{Without suppression: } R_M = \frac{V_S}{I_M} = \frac{V_S}{I_R} \left(\frac{I_R}{I_R + I_{LEAKAGE}} \right)$$

$$\text{With suppression: } R_M = \frac{V_S}{I_M - I_{LEAKAGE}} = \frac{V_S}{I_R}$$

If we connect the DUT for measurement (*Figure 14*), the resistance can then be determined based on the present measured current and the suppressed leakage current previously determined:

$$R_S = \frac{V_S}{I_M - I_{LEAKAGE}}$$

Example: Assume that $V_S = 10\text{V}$, $I_M = 11\text{pA}$, and $I_{LEAKAGE} = 1\text{pA}$. Without suppression, the measured resistance is:

$$R_S = \frac{10\text{V}}{11\text{pA}} = 909\text{G}\Omega$$

With suppression, the measured resistance is:

$$R_S = \frac{10\text{V}}{11\text{pA} - 1\text{pA}} = 1\text{T}\Omega$$

Thus, we see that suppression eliminates an error of about 9% in this example.

Guarding and Capacitive Effects

To minimize shunt currents, most electrometer amplifiers include a guard connection to their amplifier outputs. Since the guard output is a unity-gain output, the voltage potential across insulators connected between the input terminal and guard is essentially zero. In general, the same techniques used to minimize leakage current in low current measuring situations can minimize these effects in high resistance measurements.

One additional source of error in high resistance measurements is parasitic capacitance, normally associated with cables and connectors. At high resistance levels, even a few picofarads of stray capacitance can significantly affect circuit rise times and thus the settling time required for accurate measurements. For example, a $10\text{T}\Omega$ ($10^{13}\Omega$) resistance and a cable capacitance of 100pF results in an RC time constant of 1,000 seconds. Since five time constants are required for the circuit to settle to within 1%, more than 80 minutes would be required for the circuit to settle adequately.

Guarding a high resistance measurement reduces the effects of stray capacitance considerably. The effective capacitance is reduced by a factor equal to the open-loop gain of the amplifier—typically from 10^4 to 10^6 .

Common Sense Rule for Low Current Connections

Always connect the high resistance (HI) terminal of the picoammeter or electrometer to the point of highest resistance in the circuit under test. *Figure 15a* shows the correct connections, while *Figure 15b* shows incorrect connections.

Figure 15: Proper connections for current measurements

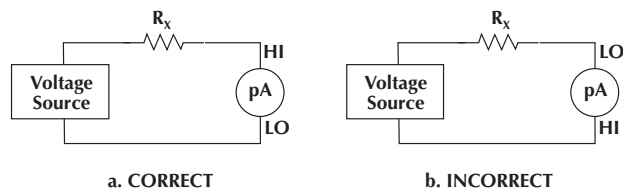

Electrometer/Picoammeter Selector Guide

Model	Features	Input Connection	Current	Voltage	Resistance	Charge
6430	6½ digits. 0.4fA _{p-p} noise. Voltage/Current Sources with Measurement. IEEE-488/RS-232 programmable.	Banana, 3-lug Triax	50aA–100mA Source 10aA–100mA Measure	5μV–200V Source 1μV–200V Measure	10μΩ–10 ¹⁷ Ω	
6517A	6½ digits. Autoranging. Low cost. Analog Output. 1000V Source. IEEE-488/RS-232 programmable.	3-lug Triax	100aA–20mA	10μV–200V	10μΩ–10 ¹⁸ Ω	10fC–2μC
6514	6½ digits. Low cost. Autoranging. Analog Output. IEEE-488/RS-232 programmable.	3-lug Triax	100aA–20mA	10μV–200V	10mΩ–200GΩ	10fC–20μC
6485	5½ digits. Autoranging. Low cost. IEEE-488/RS-232 programmable.	BNC	10fA–20mA			
486	5½ digits. Autoranging. IEEE-488/RS-232 programmable.	3-lug Triax	10fA–2mA			
487	5½ digits. Autoranging. 500V Source. IEEE-488/RS-232 programmable.	3-lug Triax	10fA–2mA			
428	Current Amplifier	BNC	1fA–16mA			

Test System Safety

Many electrical test systems or instruments are capable of measuring or sourcing hazardous voltage and power levels. It is also possible, under single fault conditions (e.g., a programming error or an instrument failure), to output hazardous levels even when the system indicates no hazard is present.

These high voltage and power levels make it essential to protect operators from any of these hazards at all times. Protection methods include:

- Design test fixtures to prevent operator contact with any hazardous circuit.
- Make sure the device under test is fully enclosed to protect the operator from any flying debris.
- Double insulate all electrical connections that an operator could touch. Double insulation ensures the operator is still protected, even if one insulation layer fails.
- Use high-reliability, fail-safe interlock switches to disconnect power sources when a test fixture cover is opened.
- Where possible, use automated handlers so operators do not require access to the inside of the test fixture or have a need to open guards.
- Provide proper training to all users of the system so they understand all potential hazards and know how to protect themselves from injury.

It is the responsibility of the test system designers, integrators, and installers to make sure operator and maintenance personnel protection is in place and effective.

Specifications are subject to change without notice.

All Keithley trademarks and trade names are the property of Keithley Instruments, Inc.
All other trademarks and trade names are the property of their respective companies.



Keithley Instruments, Inc.

28775 Aurora Road • Cleveland, Ohio 44139 • 440-248-0400 • Fax: 440-248-6168
1-888-KEITHLEY (534-8453) • www.keithley.com

Sales Offices:	BELGIUM:	Bergensesteenweg 709 • B-1600 Sint-Pieters-Leeuw • 02-363 00 40 • Fax: 02/363 00 64
	CHINA:	Yuan Chen Xin Building, Room 705 • 12 Yumin Road, Dewai, Madian • Beijing 100029 • 8610-6202-2886 • Fax: 8610-6202-2892
	FINLAND:	Tietäjantie 2 • 02130 Espoo Finland • Phone: 358 9 25105114 • Fax: 358 9 2510 5100
	FRANCE:	3, allée des Garays • 91127 Palaiseau Cédex • 01-64 53 20 20 • Fax: 01-60 11 77 26
	GERMANY:	Landsberger Strasse 65 • 82110 Germering • 089/84 93 07-40 • Fax: 089/84 93 07-34
	GREAT BRITAIN:	Unit 2 Commerce Park, Brunel Road • Theale • Reading • Berkshire RG7 4AB • 0118 929 7500 • Fax: 0118 929 7519
	INDIA:	Flat 2B, WILLOCRISSE • 14, Rest House Crescent • Bangalore 560 001 • 91-80-509-1320/21 • Fax: 91-80-509-1322
	ITALY:	Viale San Gimignano, 38 • 20146 Milano • 02-48 39 16 01 • Fax: 02-48 30 22 74
	KOREA:	FL., URI Building • 2-14 Yangjae-Dong • Seocho-Gu, Seoul 137-130 • 82-2-574-7778 • Fax: 82-2-574-7838
	NETHERLANDS:	Postbus 559 • 4200 AN Gorinchem • 0183-635333 • Fax: 0183-630821
	SWEDEN:	C/O Regus Business Centre • Frosundaviks Allé 15, 4tr • SE-169 70 Solna • Sweden • Phone: 46 8 509 04 679 • Fax: 46 8 655 26 10
	SWITZERLAND:	Kriesbachstrasse 4 • 8600 Dübendorf • 01-821 94 44 • Fax: 01-820 30 81
	TAIWAN:	1FL., 85 Po Ai Street • Hsinchu, Taiwan, R.O.C. • 886-3-572-9077 • Fax: 886-3-572-9031